

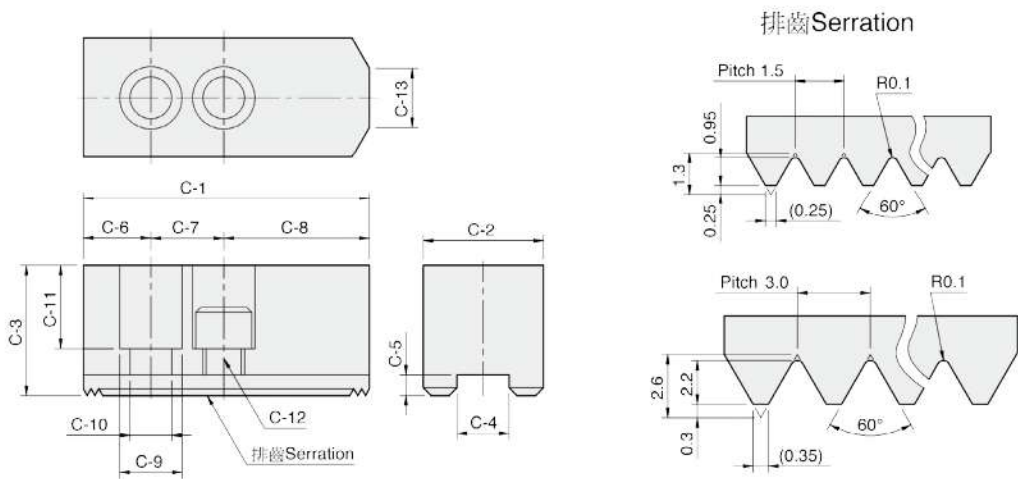

# HC

## Soft jaw for hydraulic power chuck

1. Soft jaws for hydraulic power chucks.
2. Soft jaw for CNC lathe.



| DIM Model | C-1 | C-2 | C-3 | C-4  | C-5 | C-6 | C-7 | C-8 | C-9 | C-10 | C-11 | C-12 | C-13 | Serration Pitch | Matching Chuck                            | 3 Jaw Weight (kg) |
|-----------|-----|-----|-----|------|-----|-----|-----|-----|-----|------|------|------|------|-----------------|---|-------------------|
| HC04      | 52  | 23  | 23  | 10   | 5   | 10  | 14  | 28  | 14  | 9    | 13   | M8   | 3    | 1.5x60°         | N-204                                     | 0.45              |
| HC05      | 62  | 25  | 30  | 10   | 5   | 10  | 14  | 38  | 14  | 9    | 20   | M8   | 3    | 1.5x60°         | N-205, V-205                              | 0.7               |
| HC06      | 73  | 31  | 36  | 12   | 5   | 15  | 20  | 38  | 17  | 11   | 24   | M10  | 14   | 1.5x60°         | N-206, NB-306, NL-06, V-206               | 1.5               |
| HC08      | 95  | 35  | 37  | 14   | 5   | 24  | 25  | 46  | 19  | 13   | 22   | M12  | 16   | 1.5x60°         | N-208, NB-208, NL-08, V-208               | 2.4               |
| HC10      | 110 | 40  | 42  | 16   | 5   | 30  | 30  | 50  | 19  | 13   | 27   | M12  | 18   | 1.5x60°         | N-210, NB-210, NB-310, NL-10, V-210       | 3.7               |
| HC12      | 130 | 50  | 50  | 21   | 5   | 40  | 30  | 60  | 25  | 17   | 30   | M16  | 23   | 1.5x60°         | N-212, NB-212                             | 6.5               |
| HC15      | 165 | 62  | 62  | 22   | 8   | 37  | 43  | 85  | 32  | 21   | 37   | M20  | —    | 1.5x60°         | N-215, N-218, NB-215, NB-218              | 12.5              |
| HC08-1    | 95  | 35  | 37  | 12   | 5   | 24  | 20  | 51  | 17  | 11   | 22   | M10  | 16   | 1.5x60°         | NHT-208                                   | 2.4               |
| HC12-1    | 130 | 50  | 50  | 18   | 5   | 40  | 30  | 60  | 23  | 15   | 30   | M14  | 23   | 1.5x60°         | V-212, V-212R                             | 6.6               |
| HC15-1    | 165 | 62  | 62  | 25.5 | 6   | 37  | 43  | 85  | 32  | 21   | 37   | M20  | —    | 1.5x60°         | V-215, V-218, V-215R, V-218R              | 12.5              |
| HC24-1    | 180 | 64  | 70  | 25   | 9   | 40  | 60  | 80  | 32  | 21   | 45   | M20  | —    | 3.0x60°         | N-220, N-224, V-221, V-224 V-221R, V-224R | 15.8              |
| HC32-1    | 210 | 74  | 90  | 25   | 9   | 40  | 80  | 90  | 32  | 21   | 65   | M20  | —    | 3.0x60°         | V-232R                                    | 29.2              |
| HC15-2    | 156 | 64  | 70  | 26   | 9   | 34  | 50  | 72  | 32  | 21   | 45   | M20  | —    | 3.0x60°         | V-215(P3.0), V-218(P3.0)                  | 13.4              |

UNIT : mm

## Soft jaw for draw down power chuck

UNIT : mm

| DIM Model | C-1 | C-2 | C-3  | C-4 | C-5 | C-6 | C-7 | C-8 | C-9 | C-10 | C-11 | C-12 | C-13 | Matching Chuck | 3 Jaw Weight (kg) | Reference |
|-----------|-----|-----|------|-----|-----|-----|-----|-----|-----|------|------|------|------|----------------|-------------------|-----------|
| DR-06     | 70  | 35  | 34   | 10  | 6   | 43  | —   | 10  | 23  | 15.5 | 21   | M14  | 2.5  | DR-06          | 1.5               | Fig-1     |
| DR-08     | 84  | 40  | 44.5 | 16  | 7   | 53  | 26  | 12  | 20  | 13.5 | 29   | M12  | 3.5  | DR-08          | 2.7               | Fig-2     |
| DR-10     | 100 | 50  | 49.5 | 18  | 7   | 62  | 32  | 15  | 23  | 15.5 | 32   | M14  | 3.5  | DR-10          | 4.6               | Fig-2     |
| DR-12     | 120 | 60  | 54.5 | 20  | 7   | 78  | 36  | 17  | 26  | 17.5 | 36   | M16  | 3.5  | DR-12          | 7.5               | Fig-2     |

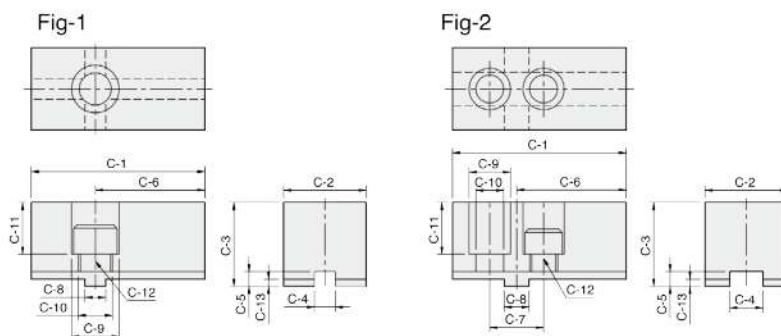

## Soft jaw for ball swing lock chuck

UNIT : mm

| DIM Model | C-1 | C-2 | C-3 | C-4  | C-5 | C-6 | C-7   | C-9 | C-10 | C-11 | C-12 | Matching Chuck | 3 Jaw Weight (kg) |
|-----------|-----|-----|-----|------|-----|-----|-------|-----|------|------|------|----------------|-------------------|
| BL-12     | 108 | 70  | 70  | 57.1 | 3.3 | 19  | 44.45 | 25  | 17   | 59   | M16  | BL-12          | 10.6              |

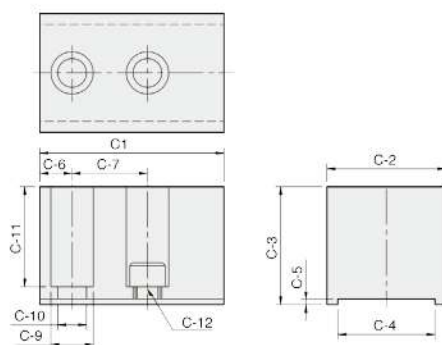

## Soft jaws for pneumatic power chuck

UNIT : mm

| DIM Model | C-1 | C-2 | C-3 | C-4  | C-5 | C-6 | C-7 | C-8 | C-9 | C-10 | C-11 | C-12 | C-13  | Matching Chuck | 3 Jaw Weight (kg) |
|-----------|-----|-----|-----|------|-----|-----|-----|-----|-----|------|------|------|-------|----------------|-------------------|
| PB600     | 205 | 60  | 60  | 25.5 | 6   | 25  | 38  | 104 | 32  | 21   | 44   | M20  | 55    | PB-ES600       | 13.5              |
| PB850     | 320 | 80  | 80  | 30   | 7   | 35  | 60  | 165 | 38  | 26   | 53   | M24  | 110.5 | PB-ES850       | 40.2              |

