

# T-NUTS

## T型塊

Suitable for power chuck

· 適用於油壓夾頭。



產品示意圖

Fig. 1

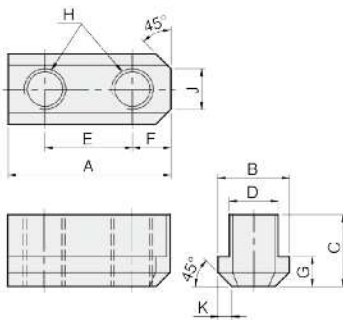

Fig. 2

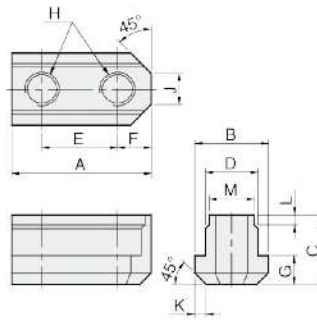
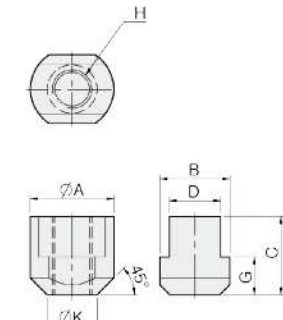

Fig. 3



單位：mm

型 式 尺 寸	A	B	C	D	E	F	G	H	J	K	L	M	Fig	適合夾頭
N-205	26	14.5	15	10	14	6	5.5	M8	5	2	—	—	1	N-204, N-205
N-206	36	17.5	18.5	12	20	8.2	7.5	M10	8	2.5	—	—	1	N-206, NB-306, NL-06
N-208	46.5	20.5	20.5	14	25	10.5	8.5	M12	12	4	—	—	1	N-208, NB-208, NL-08
N-210	51	22.5	21.5	16	30	11	8.5	M12	11	3	—	—	1	N-210, NB-210, NL-10
N-212	55.5	29.5	27.8	21	30	12	11.5	M16	13	4.5	—	—	1	N-212, NB212
N-215	80	33.5	45.5	24	43	17	16.5	M20	11	5	8	22	2	N-215, N-218
V-206	36.5	17.5	22.5	12	20	7.5	7.5	M10	6	3	—	—	1	V-206, NHT-208
V-208	48	20.5	25.5	14	25	11	9.5	M12	8	4	—	—	1	V-208
V-210	55	22.5	25.5	16	30	11	9.5	M12	8	4	—	—	1	V-210
V-212	55.5	26.5	33.5	18	30	11.5	13.5	M14	11	5	—	—	1	V-212
V-215	42	35	39.2	25.5	—	—	19	M20	—	25	—	—	3	V-215, V-218
V-215 26 M20	42	35	41.2	26	—	—	19	M20	—	25	—	—	3	V-215P3.0
V-224	46	37.5	45	25	—	—	19	M20	—	26.5	—	—	3	N-220, N-224, V-221, V-224, V-232